

TRIPLE TYPES

Dutchclamp® Triple cable clamps are specially designed for short-circuit resistant fastening of cables in trefoil applications. Triple types are available in 6 models and suitable for cables with a diameter from 27 mm to 150 mm.

Dutchclamp® Triple cable clamps are unique in their kind. The surfaces wherein the cables come to lie ensure perfect pressure distribution and maximum grip on the cables without sharp edges. In this way, there is no point load on the cables and the cables are not damaged. The Triple cable clamps are also stackable. Dutchclamp® Triple cable clamps are manufactured from the highest quality glass fibre reinforced polyamide and are therefore ideally suited for installations where high short circuit forces may occur.

The unique raw material used in manufacturing these cable clamps, makes them resistant to corrosion, ozone, frost, heat, oil, acids, salts, aggressive chemicals, UV and nuclear radiation. There is no reduction in force within temperatures from -40° C to + 125° C (momentarily up to 225° C).

Dutchclamp® Triple cable clamps have been tested by, among others, **UL (The Underwriters Laboratories U.S.A) Voltalab** in Grenoble (**Schneider**), the **Prof. Ir. Damstra laboratory (Eaton) KEMA** and **SGS Brussels** in accordance with the **NEN-EN-IEC 61914:2009** international standard. (All test reports are available upon request).

Dutchclamp® Triple cable clamps are used worldwide and are therefore available from stock. They can also be supplied with appropriate fastening material.

Dutchclamp®

Cable clamps - Cable blocks

Certified in accordance with the NEN-ENIEC 61914:2009 international safety standard

Dutchclamp has been developing and producing innovative cable clamps and cable blocks for installation of low, medium and high voltage cables since 1982. The clamps have been designed in close collaboration with major energy companies.

Dutchclamp is globally renowned for its quality, service and reliability. The Dutchclamp cable clamps and cable blocks are now being successfully used in more than 50 countries around the world.

The design

By way of the specific unique model, each type of cable clamp provides an exact fit for the required short-circuit resistant installation.

The raw material

Dutchclamp cable clamps are produced from high-quality virgin raw materials, with glass fibre reinforced polyamide as the main ingredient. The Dutchclamp cable clamps are self extinguishing and halogen free.

Robustness

Owing to the unique design combined with the specific composition of the raw materials, these plastic cable clamps are among the strongest in the world. They are specially designed to withstand the enormous forces that occur during short circuiting and have been tested by various laboratories.

Tests

The cable clamps have been tested by, among others, UL (The Underwriters Laboratories U.S.A), Prof. Ir. Damstra Laboratory (Eaton), Volta laboratory in Grenoble (Schneider), KEMA and SGS Brussels, in accordance with the NEN-EN-IEC 61914:2009 international standard. (all test reports are available upon request)

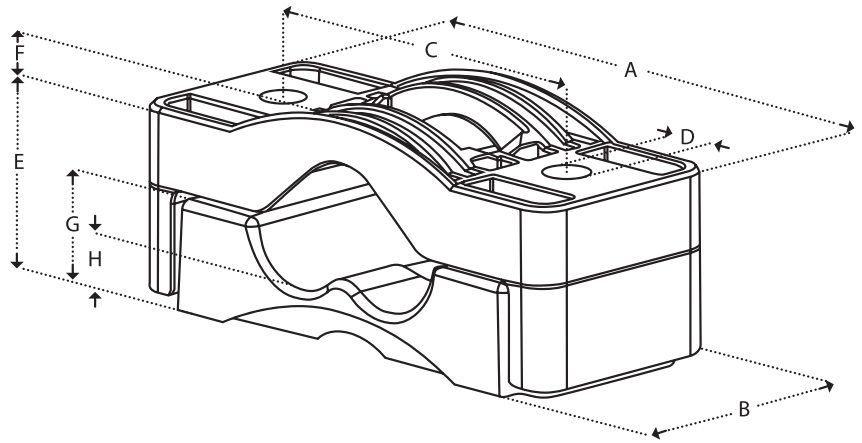

| Dimensions in mm. | | | | | | | | | |
|-------------------|--------------|-----|-----|-----|------|-----|----|-----|------|
| Type | cable ø | A | B | C | D | E | F | G | H |
| TRIPLE 27 - 38 | 3x 27 - 38 | 180 | 75 | 125 | 15.5 | 63 | 12 | 35 | 16.5 |
| TRIPLE 38 - 51 | 3x 38 - 51 | 195 | 80 | 145 | 15.5 | 84 | 16 | 45 | 20 |
| TRIPLE 51 - 69 | 3x 51 - 69 | 220 | 85 | 170 | 15.5 | 109 | 21 | 58 | 26 |
| TRIPLE 69 - 90 | 3x 69 - 90 | 252 | 90 | 215 | 15.5 | 134 | 29 | 72 | 30 |
| TRIPLE 90 - 118 | 3x 90 - 118 | 321 | 100 | 270 | 15.5 | 180 | 27 | 89 | 33 |
| TRIPLE 118 - 150 | 3x 118 - 150 | 400 | 110 | 340 | 15.5 | 211 | 37 | 110 | 75 |

ADVANTAGES

- Resistant to short-circuit currents / forces up to 150 Ka.
- Resistant to oils, fats, aggressive chemicals, frost, heat, UV, ozone, salt, moisture, acids, and nuclear radiation.
- Self-extinguishing V-0 (UL94), Halogen free.
- Temperature range from -40 °C to 125°C. (225°C) momentarily.
- Coloured black.
- No magnetism / conductivity.
- Custom mounting available.
- Fastening materials can be supplied to size.
- No oxidation / corrosion.
- No sharp angles.
- Recyclable.
- Lifetime warranty.
- Very simple installation.
- Available worldwide.
- Stackable.
- Certified in accordance with NEN-EN-IEC 61914:2009

